

de - Montageplan für vollintegrierte Geschirrspüler

Bitte beachten Sie diesen Montageplan und lesen Sie unbedingt die Gebrauchsanweisung vor der Aufstellung - Installation - Inbetriebnahme. Dadurch schützen Sie sich und vermeiden Schäden an Ihrem Gerät.

en - Installation drawings for fully integrated dishwashers

To avoid the risk of accidents or damage to the dishwasher please observe this installation sheet and read the operating instruction manual supplied with it before it is installed or used for the first time.

da - Monteringsanvisning til fuldintegrerbare opvaskemaskiner

Følg venligst denne monteringsplan, og læs brugsanvisningen inden opstilling, installation og ibrugtagning for at undgå skader på personer og produkt.

fi - Täysintegroituviien astianpesukoneiden asennuskaavio

Noudata tätä asennuskaaviota ja lue ehdottomasti mukana toimitettu käyttöohje ennen astianpesukoneen asennusta, liittäntöjää ja käyttöönottoa. Näin vältät mahdolliset vahingot ja laitteesi rikkoutumisen.

no - Monteringsanvisning for fullintegrerte oppvaskemaskiner

Følg denne monteringsanvisningen og les brugsanvisningen for oppstilling – installasjon – igangsetting. Dermed unngår man ulykker og skader på maskinen.

sv - Monteringsanvisning för helintegrerade diskmaskiner

Följ monteringsritningen och läs brugsanvisningen innan maskinen ställs upp - installeras - tas i bruk. Därigenom undviks olyckor och skador på maskinen.

ru - Монтажный план для полностраиваемых посудомоечных машин

Пожалуйста, соблюдайте указания этого монтажного плана и обязательно прочитайте инструкцию по эксплуатации перед установкой, монтажом и вводом в эксплуатацию машины. Этим вы защитите себя и предотвратите повреждения вашей машины.

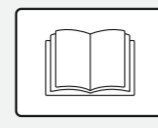

Gebrauchsanweisung beachten.
See operating instruction manual.
Følg venligst brugsanvisningen.

Noudata käyttöohjetta.

Følg brugsanvisningen.

Beakta brugsanvisningen.

Соблюдайте указания инструкции по эксплуатации.



Beschädigung oder Brandgefahr.
Risk of damage or fire hazard.
Risiko for beskadigelse eller brand.

Vahingon tai tulipalon vaara.

Fare for skade eller brann.

Skaderisk eller brandfara.

Опасность повреждений или возгорания.



Anschlusswerte beachten.
Check connection data.
Tilslutningsværdierne skal overholdes.

Tarkista sähköliitännätiedot.

Ta hensyn til tilkoblingsdata.

Beakta anslutningsdata.

Учитывайте параметры подключения.



Vor dem Verschieben des Geschirrspülers FüÙe eindrehen.
Screw the feet in before moving the dishwasher.

Benene skal justeres ind, inden maskinen flyttes.

Kierrä säätöjalat sisään ennen kuin siirät astianpesukonetta.

Før du flytter på oppvaskmaskinen må maskinføttene skrues inn.
Innan diskmaskinen flyttas ska skruvöföterna skrivas in.

Перед перемещением посудомоечной машины необходимо вернуть ножки.

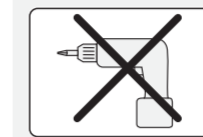

Keinen Akkuschauber verwenden, Beschädigungsgefahr.
Do not use a cordless screwdriver, risk of damage.

Anvend ikke skruemaskine - risiko for beskadigelse.

Älä käytä akkukäyttöistä ruuviväännintä. Vaurioiden vaara.

Ikke bruk batteridrevet drill. Fare for skade.

Använd inte en batteridrivnen skruvdragare. Skaderisk.

He iisпользовать шурупёрт, опасность повреждений.



Türfedern nach Montage der Frontplatte unbedingt auf beiden Seiten gleichmäßig einstellen.

The door springs must be set equally on both sides after fitting the front panel to the door.

Dorfjædrene skal ubetinget justeres ens i begge sider efter montering af frontpladen.

Muista ehdottomasti säätää luukun jousitus molemmilta puolilta samanaiseksi kalusteoven/peitelevyn asentamisen jälkeen.

Etter at frontplaten er montert, må dorfjærene justeres likt på begge sider.

Justera ovillkorligen luckans fjädrar lika på båda sidorna när du har monterat frontplattan.

После монтажа фронтальной панели необходимо отрегулировать дверные пружины симметрично с обеих сторон.



Achtung Schnittgefahr.
Warning: Danger of being cut.
Advarsel: Risiko for at skære sig.

Varo. Viiltohaavan vaara.

Advarsel: Fare for kuttskader.

Obs. Risk för skårskada.

Осторожно: опасность получения порезов.

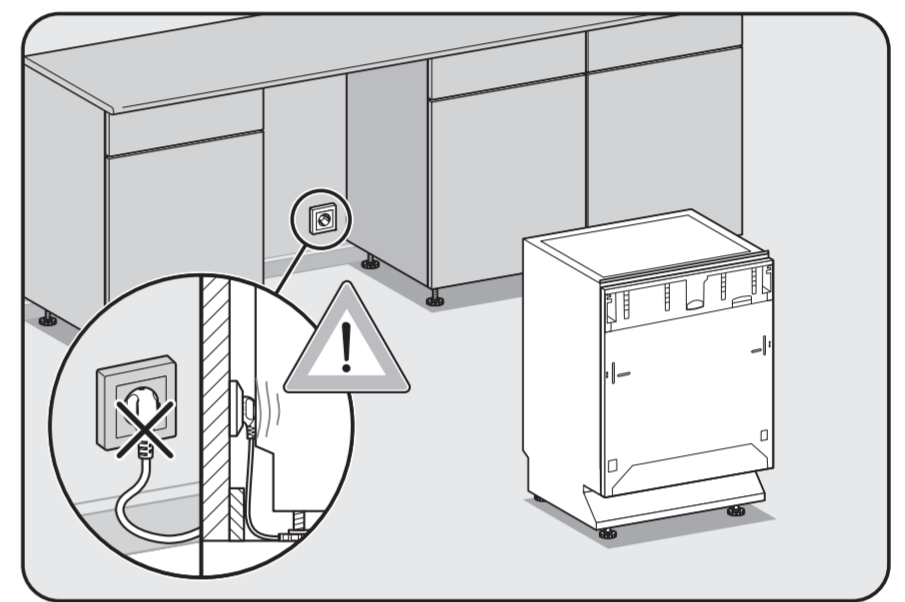
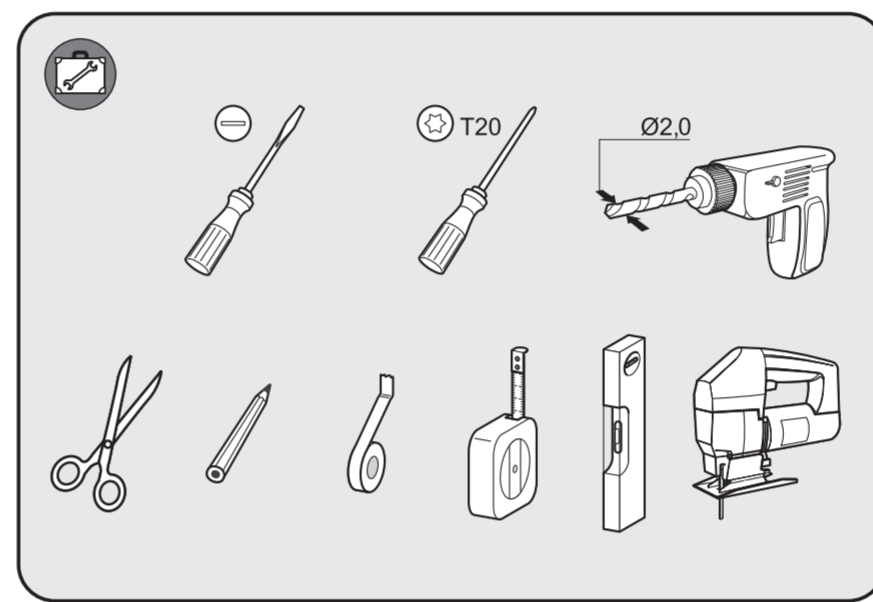
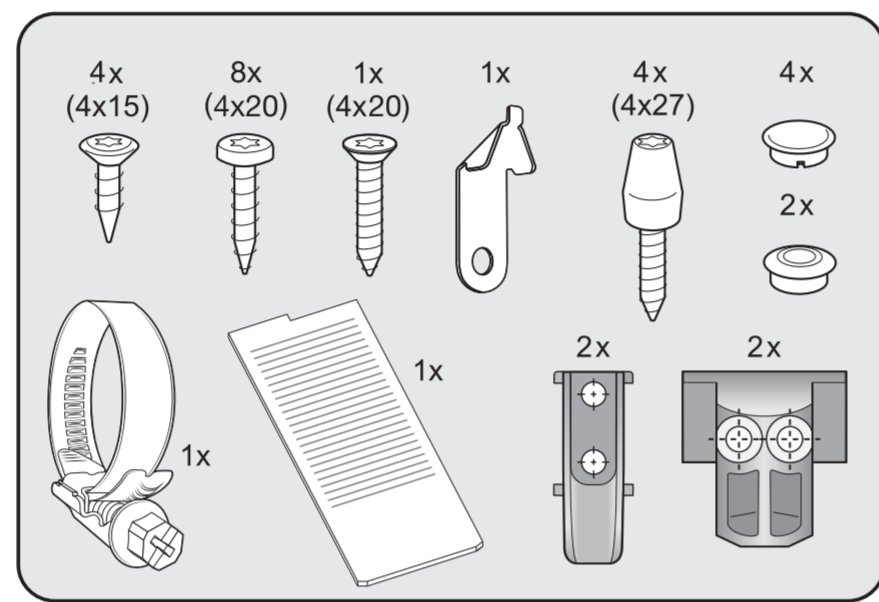
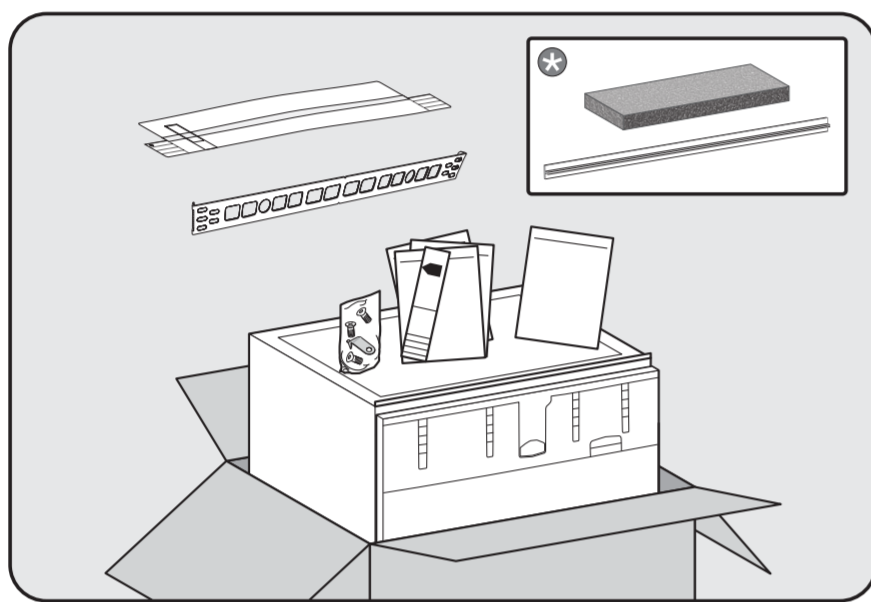

Je nach Modell beiliegendes Montagezubehör.
Fittings supplied depend on model.
Medfølgende monteringstilbehør afhængig af model.
Mukana toimitetut asennustarvikkeet (mallin mukaan).

Vedlagt monteringstilbehør, afhængig af model.
Medfølgende monteringstilbehør berende på model.
Монтажная принадлежность в комплекте поставки, в зависимости от модели.

Je nach Modell benötigtes Werkzeug.
Tools required depend on model.
Nødvendigt værktøj afhængig af model.
Tarvittavat työkalut (mallin mukaan).

Nødvendig værktøj, afhængig af model.
Værktøj som behøvs berende på model.
Необходимый инструмент, в зависимости от модели.

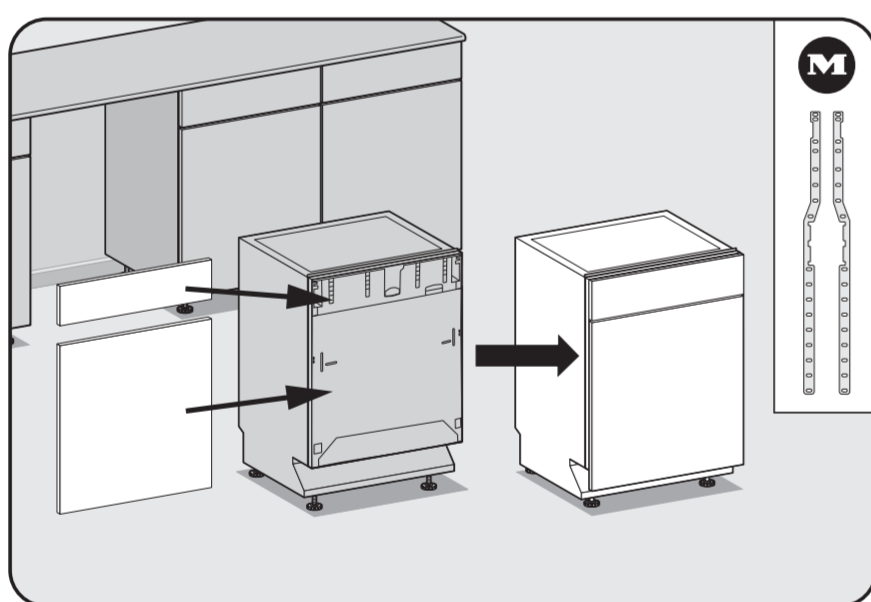
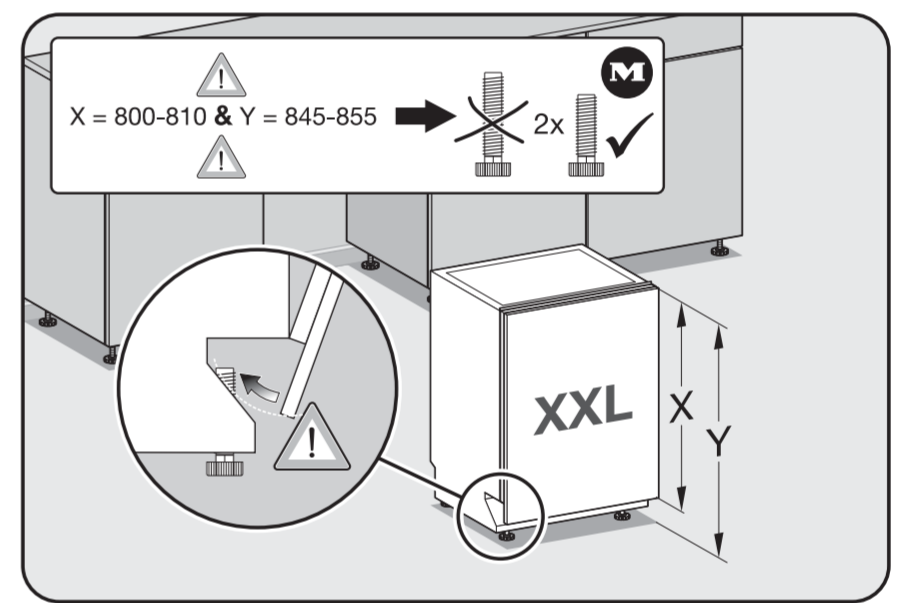
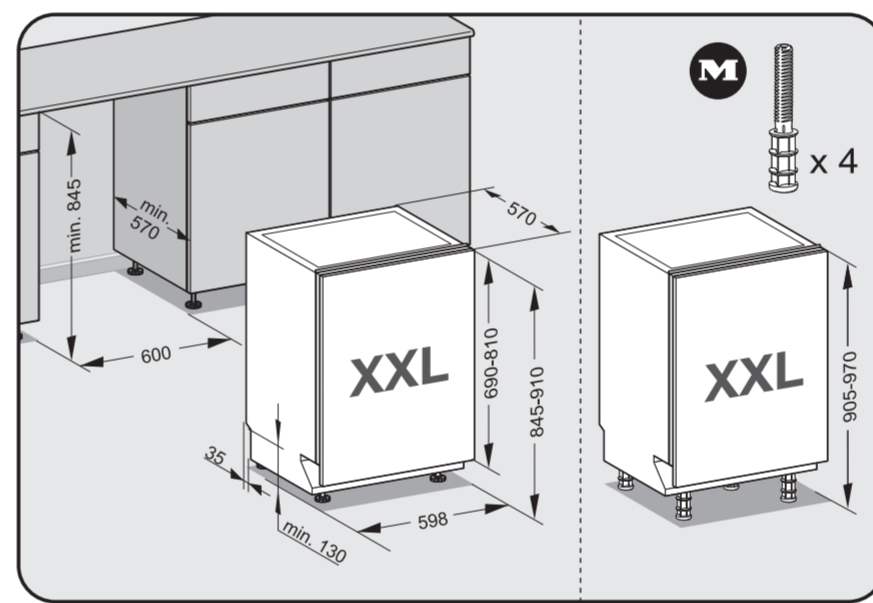
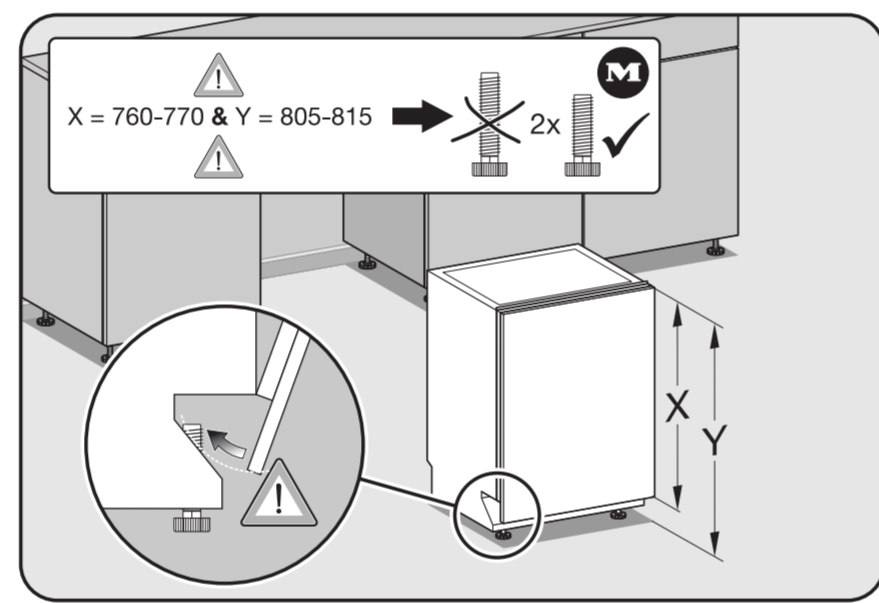
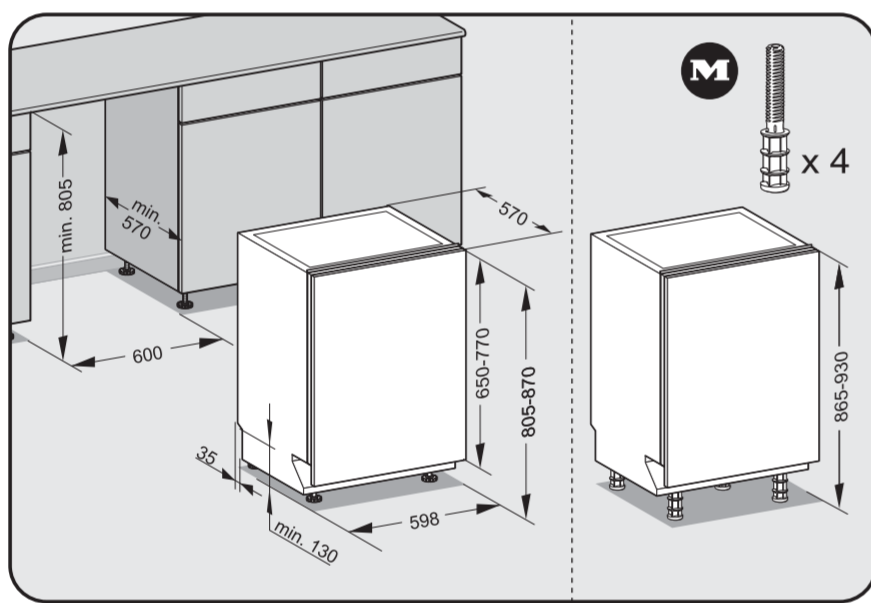

M Nachkaufbares Zubehör
Optional accessories
Ekstra tilbehør
Erikseen ostettava lisävaruste
Ekstra tilbehør
Дополнительно приобретаемая принадлежность

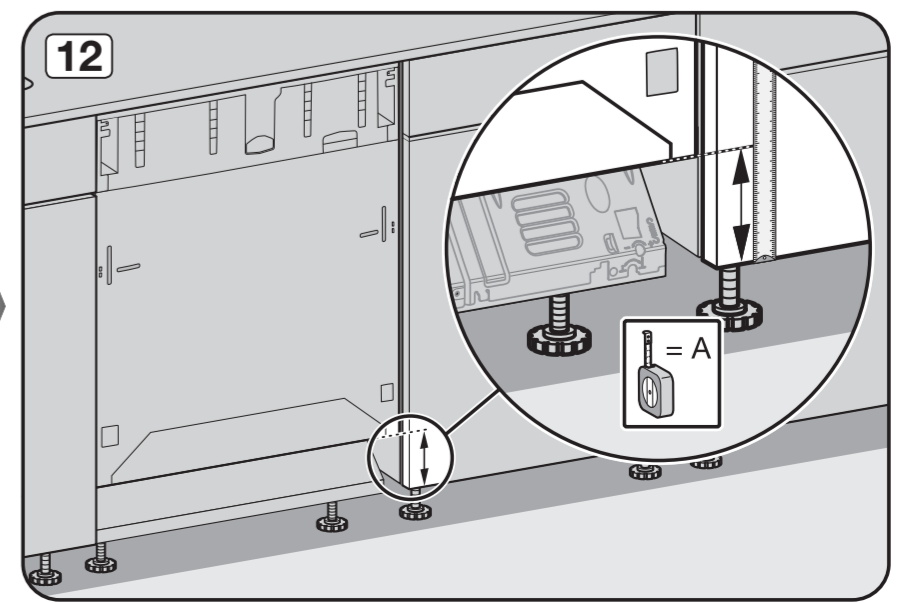
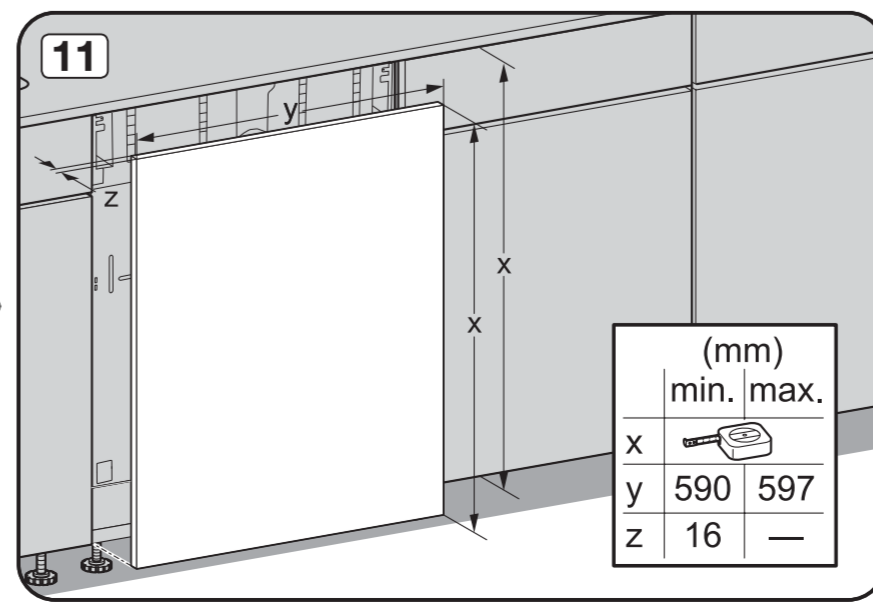
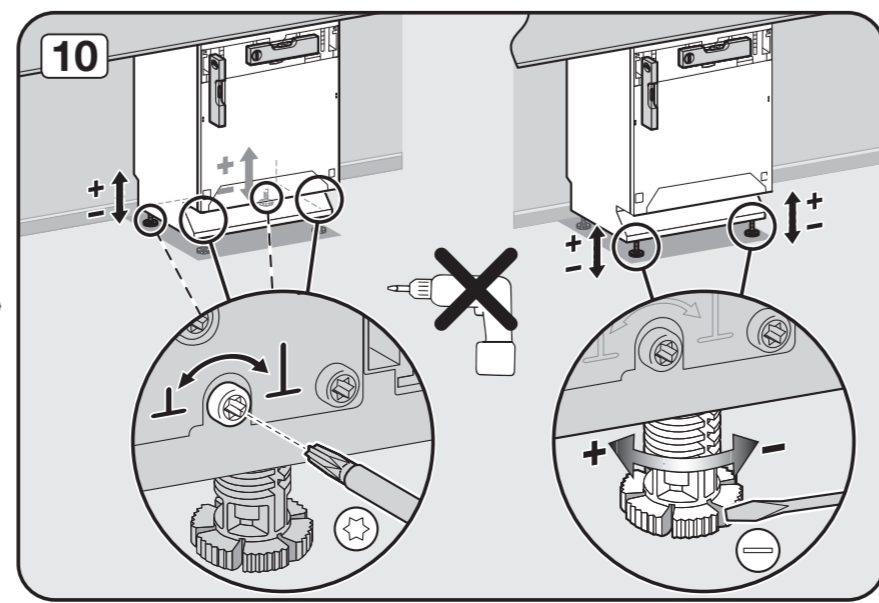
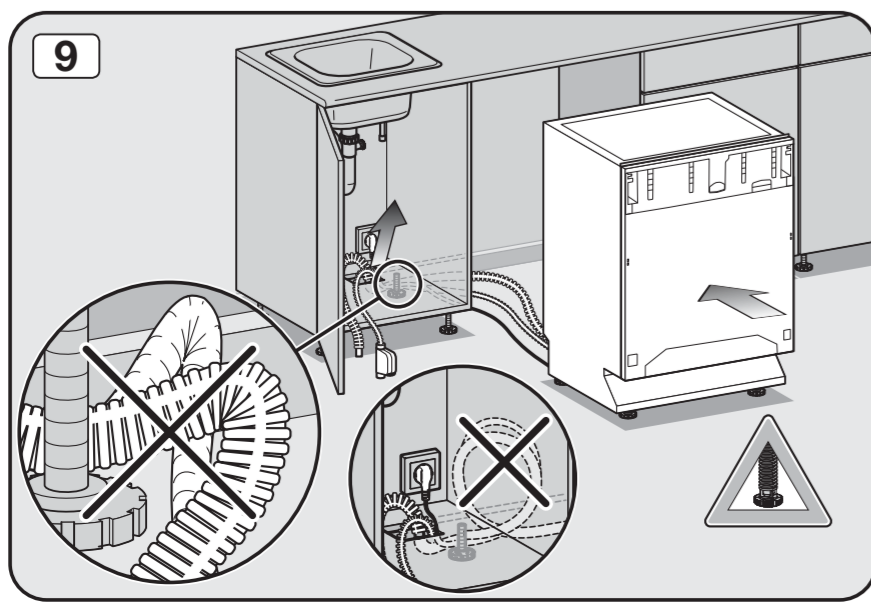
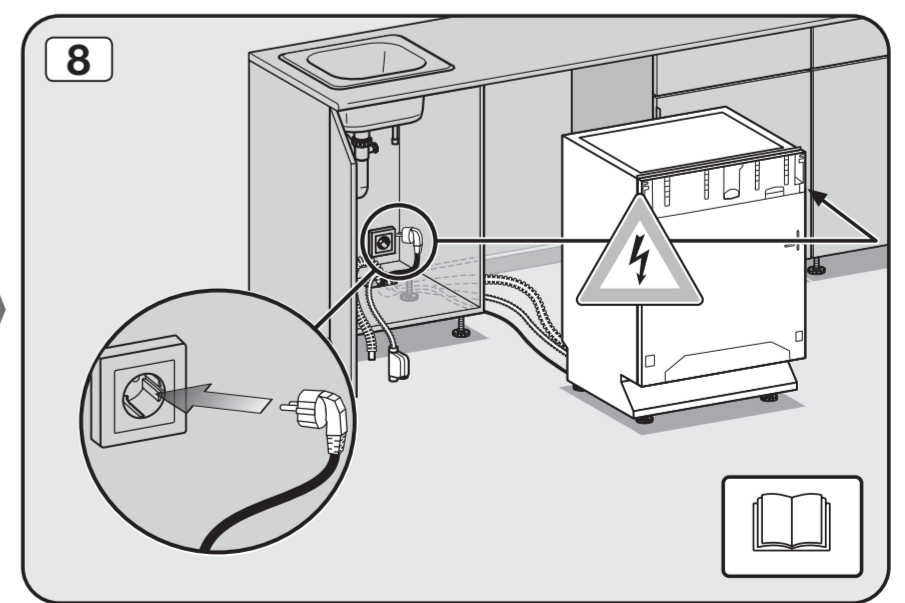
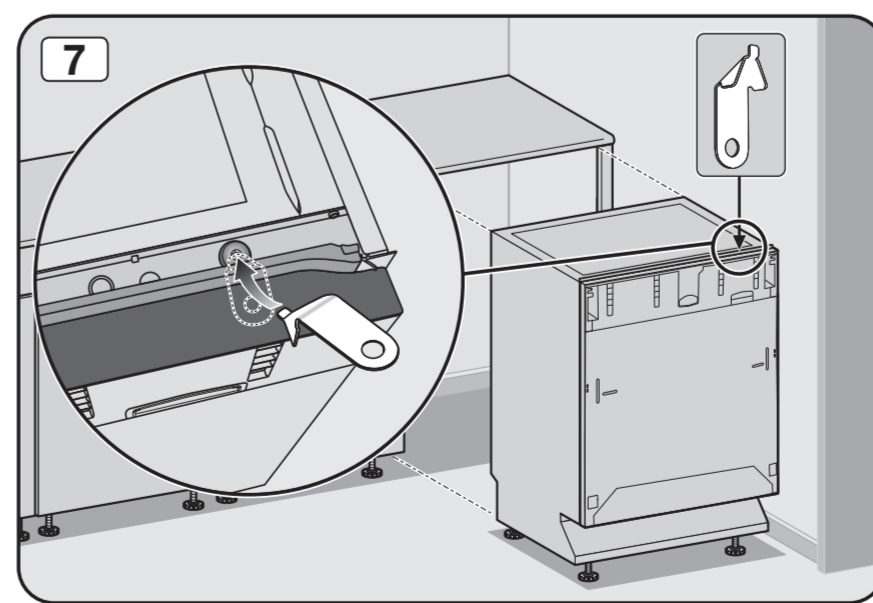
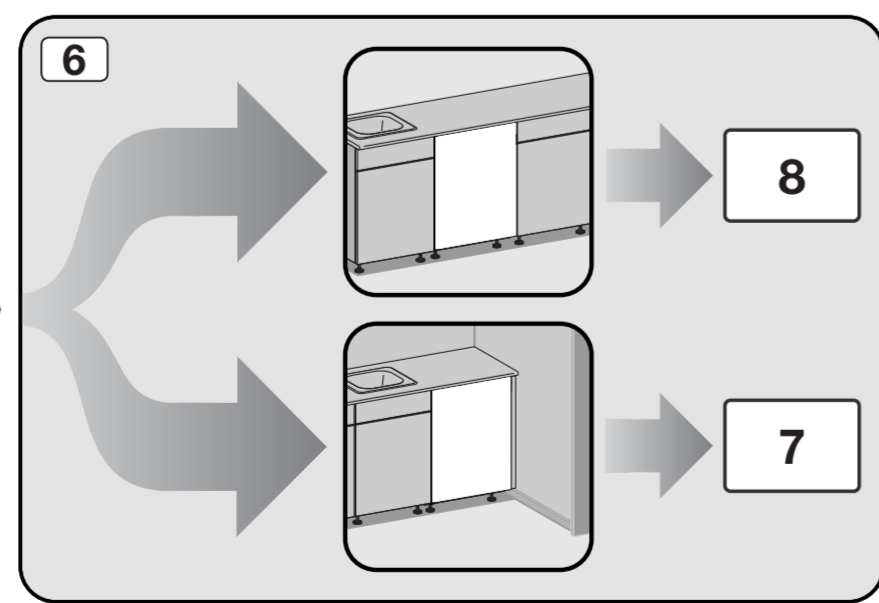
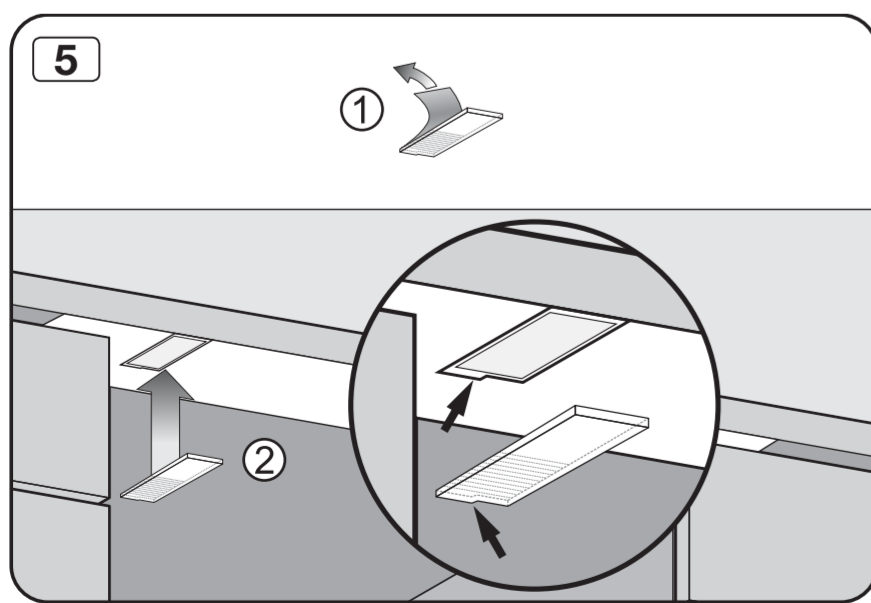
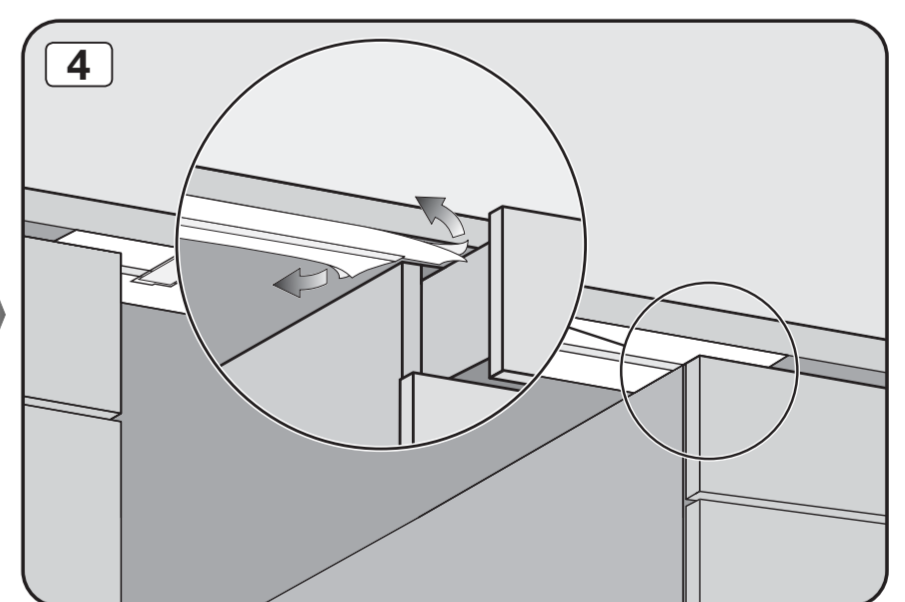
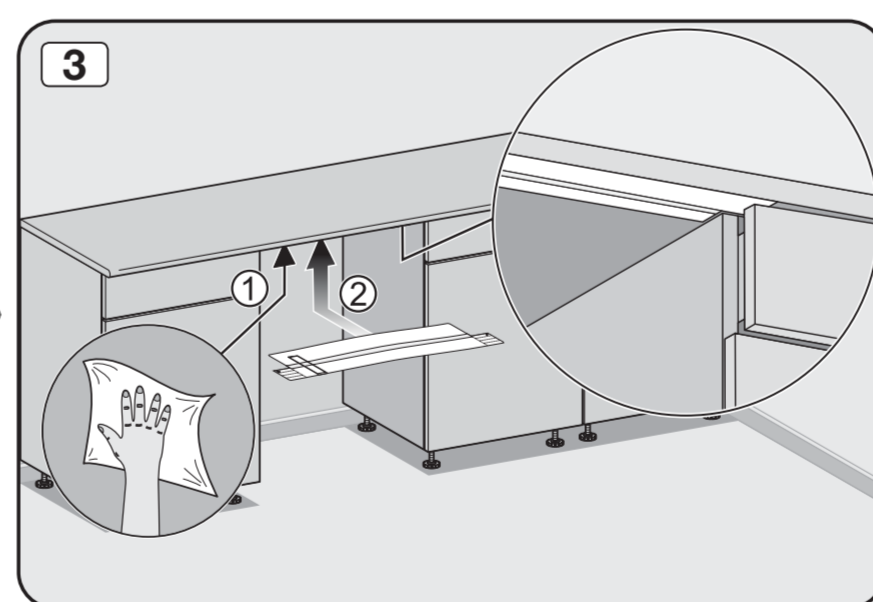
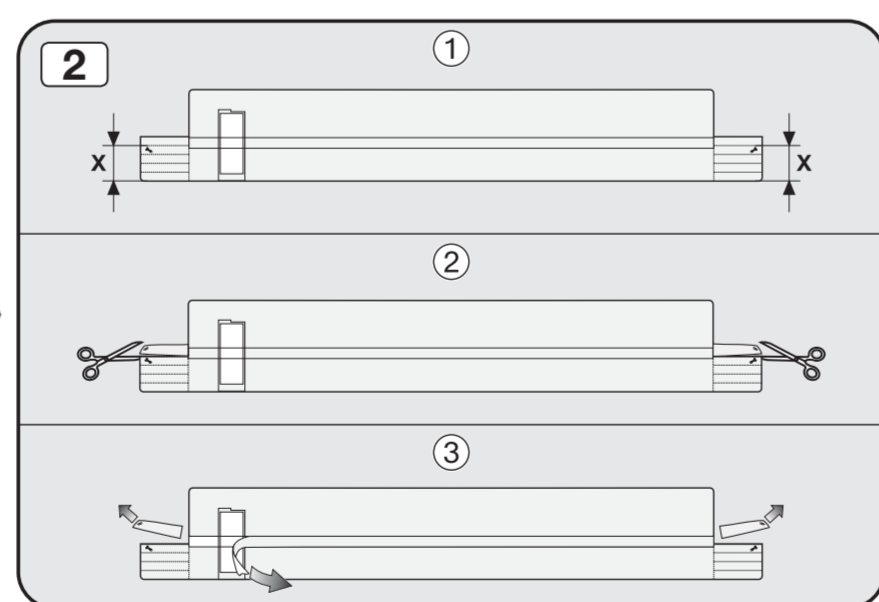
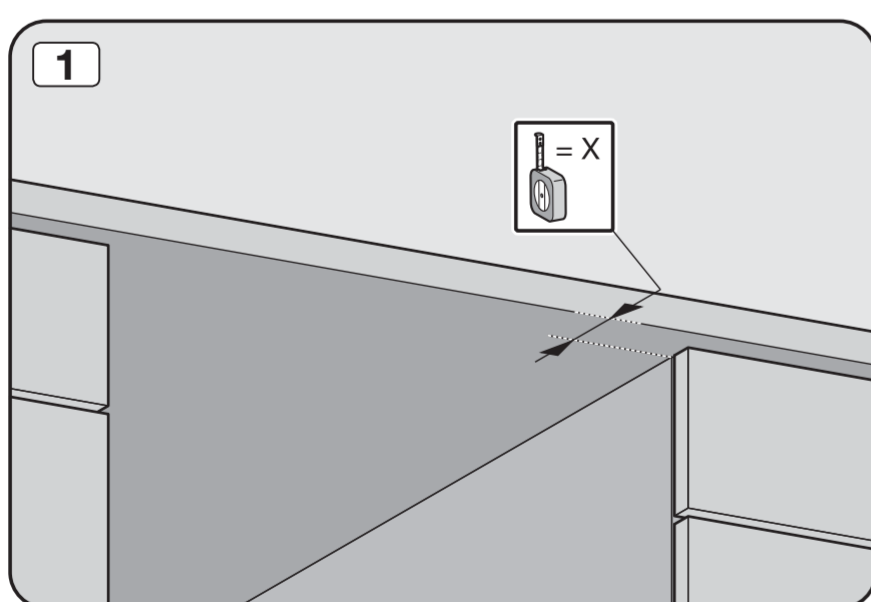

	(mm)	min.	max.
x		590	597
y		590	597
z		16	—

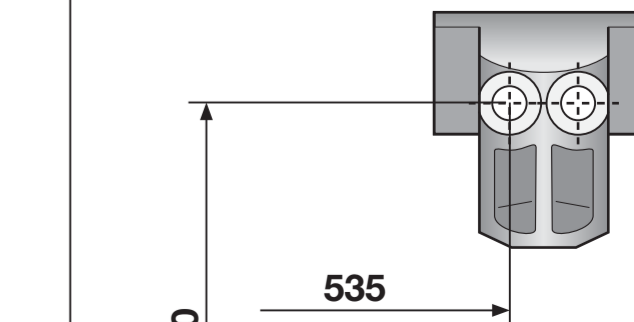
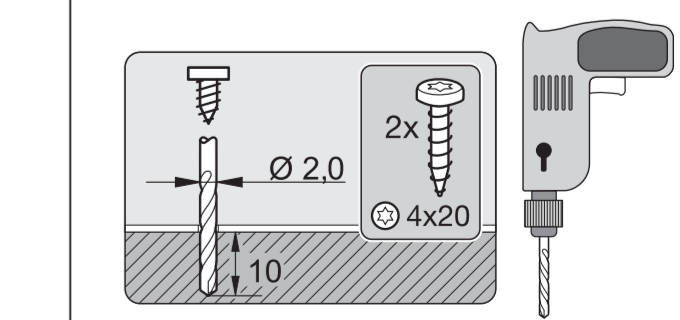
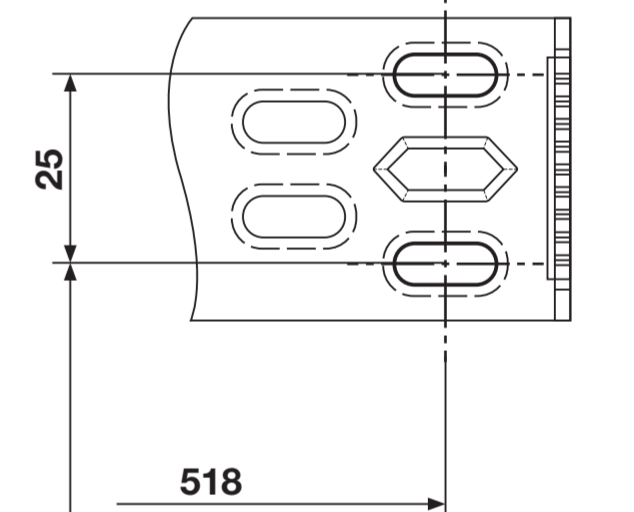
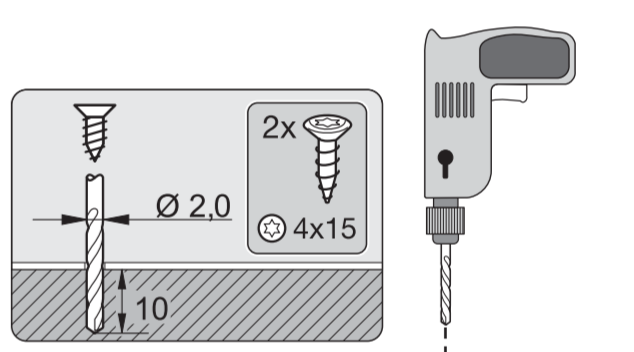
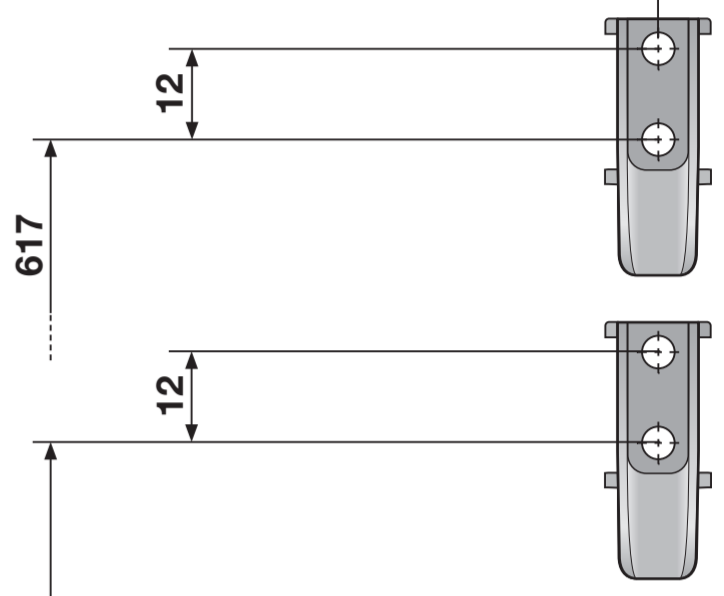
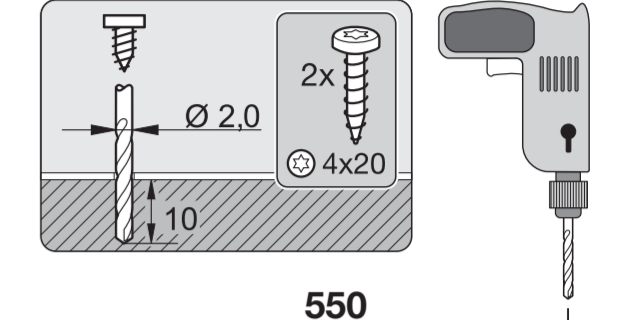
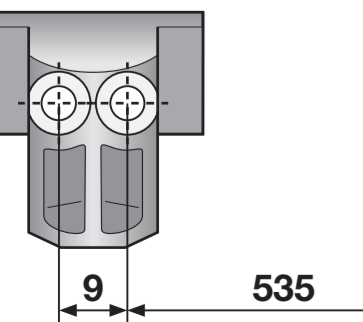
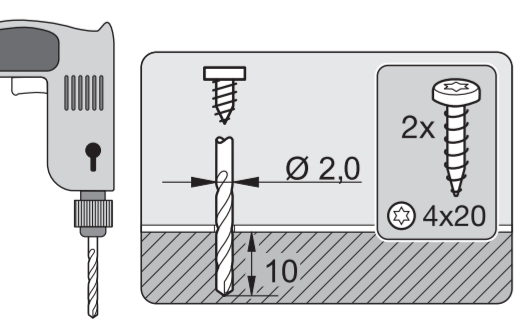
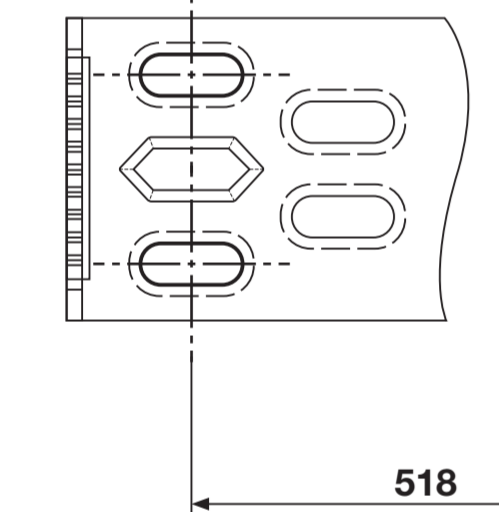
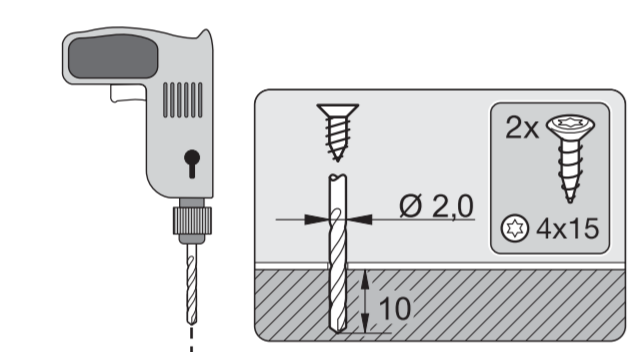
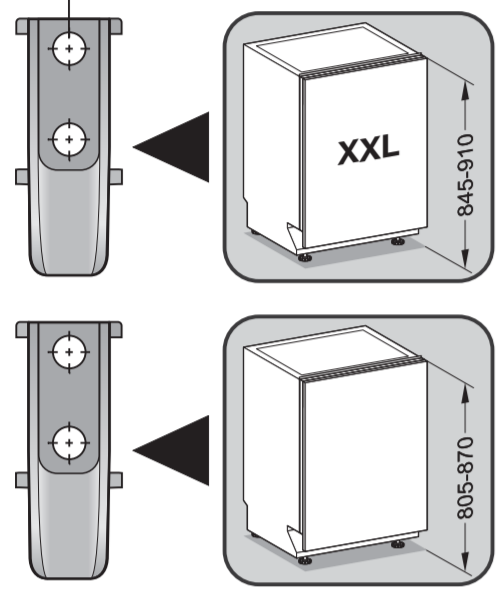
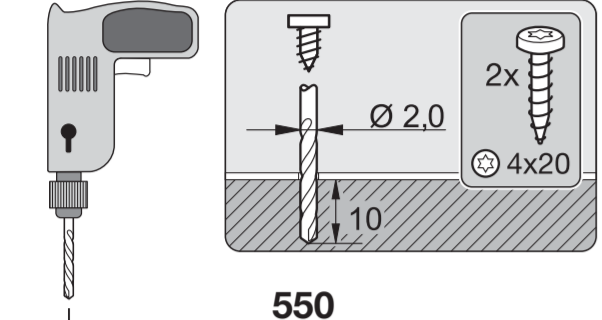
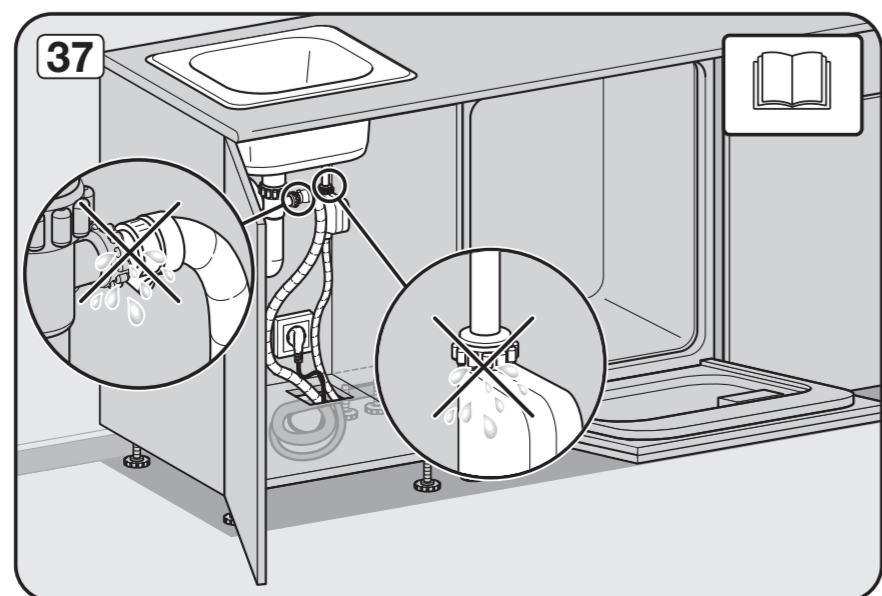
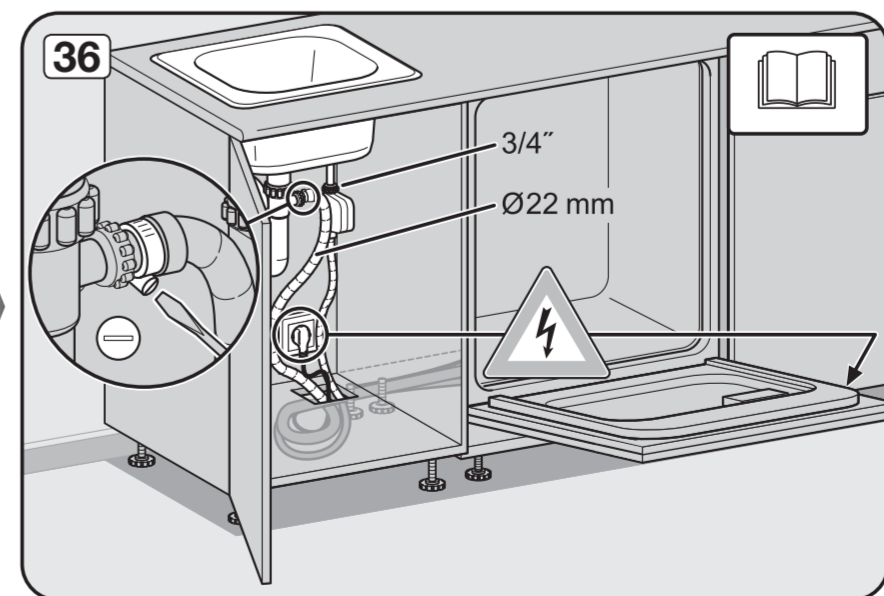
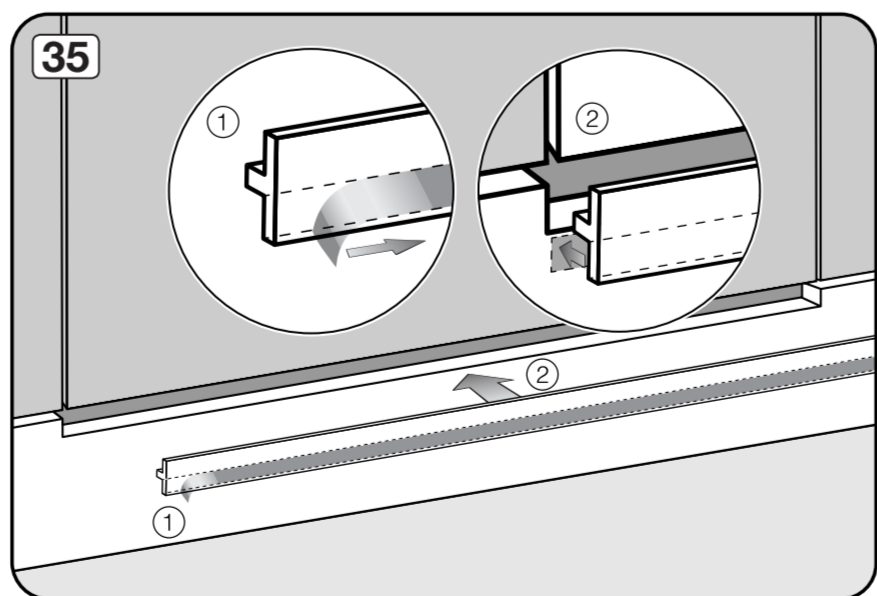
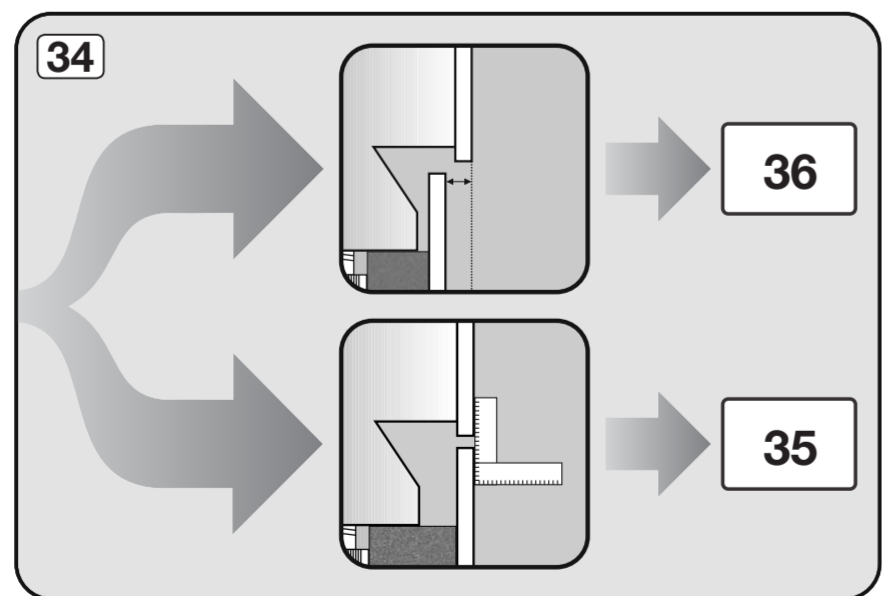
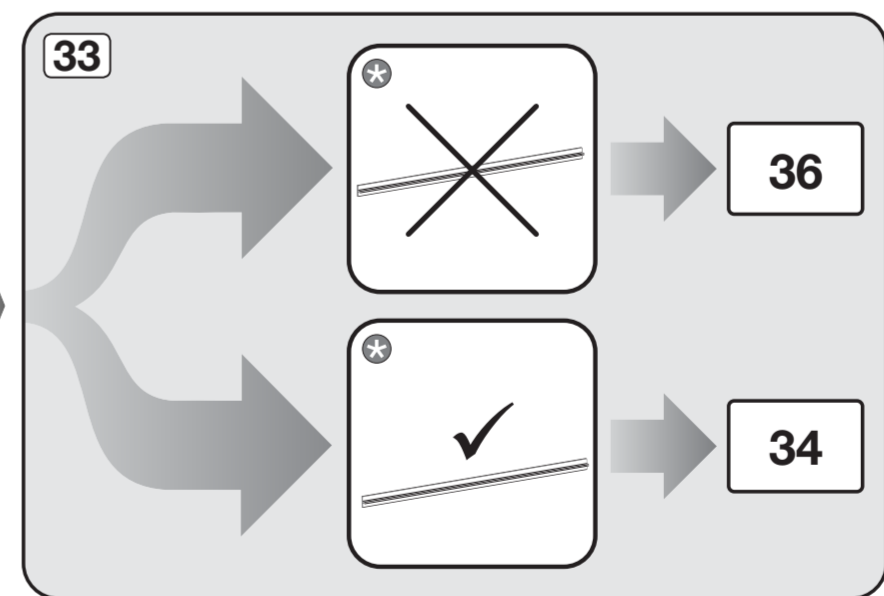
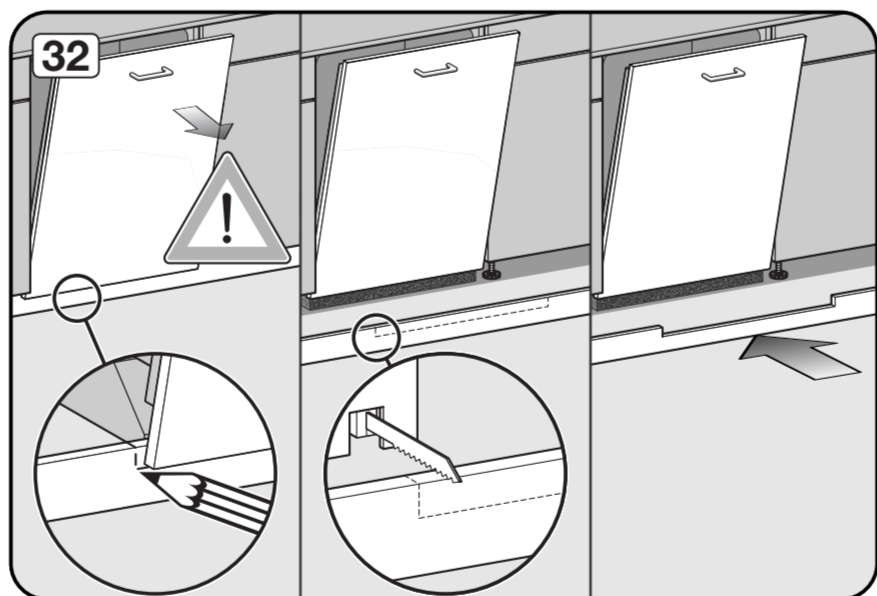
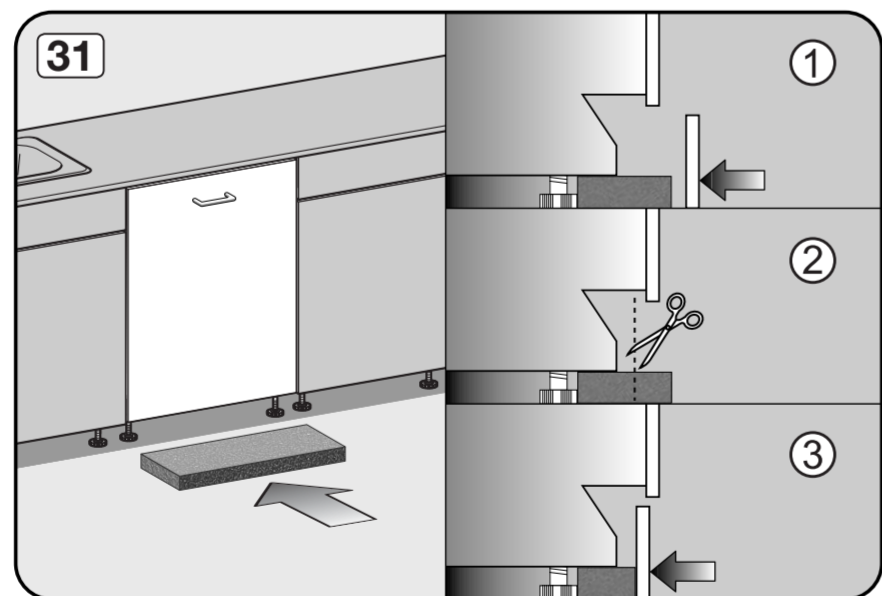
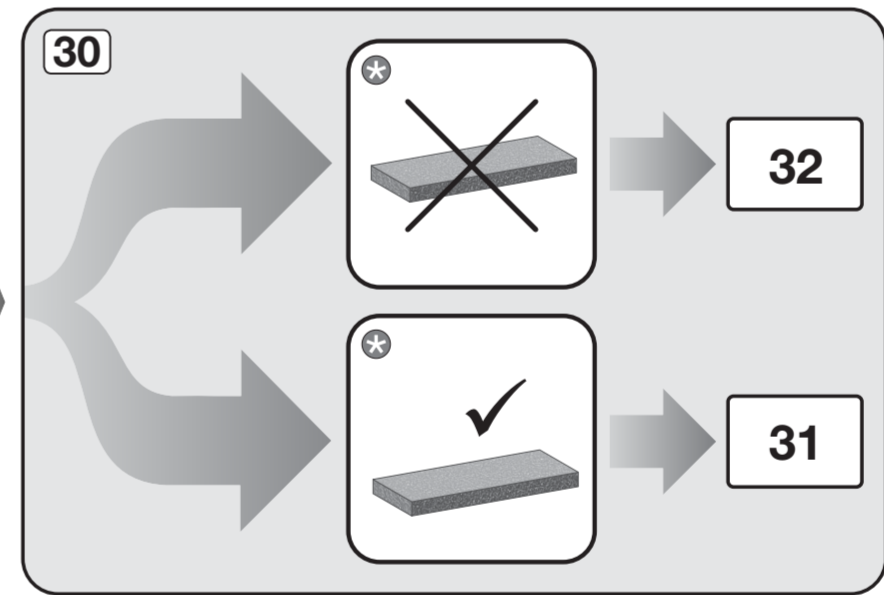
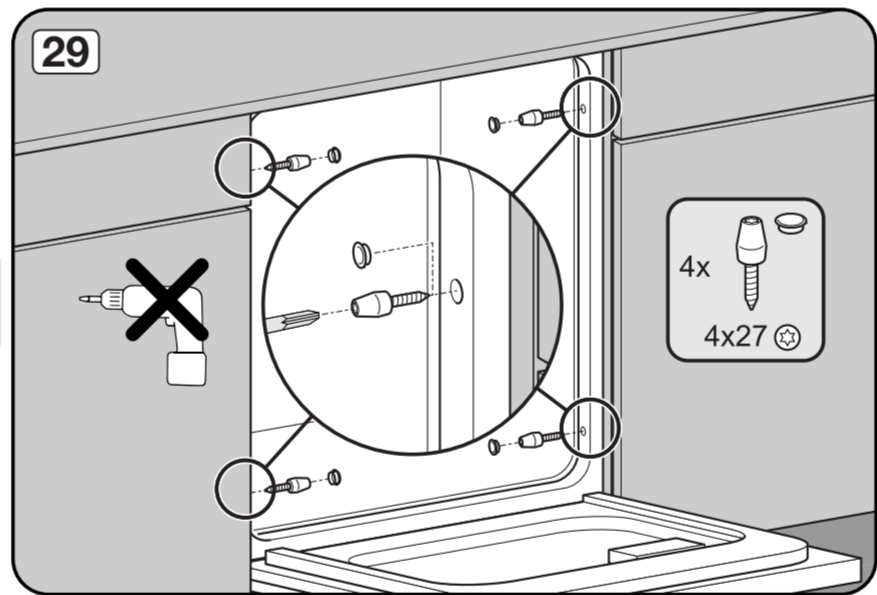
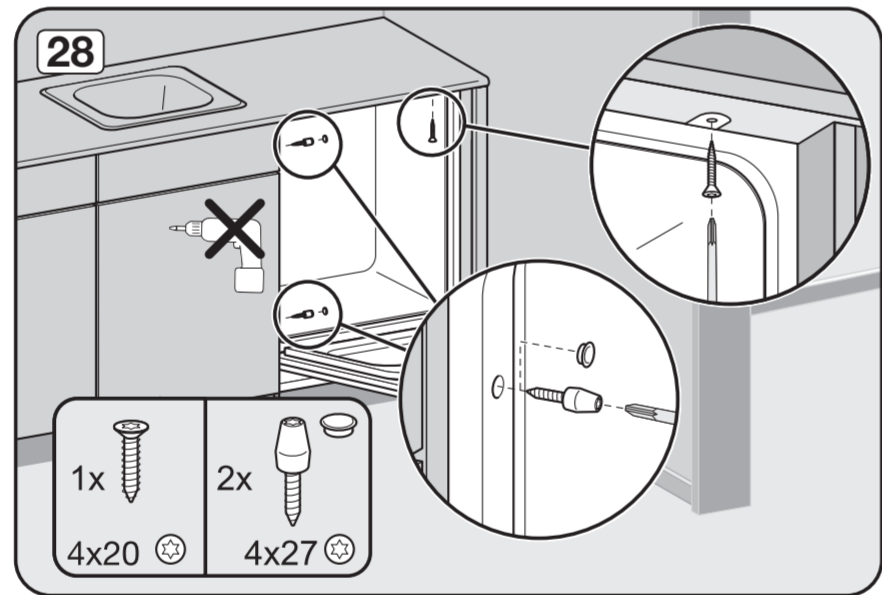
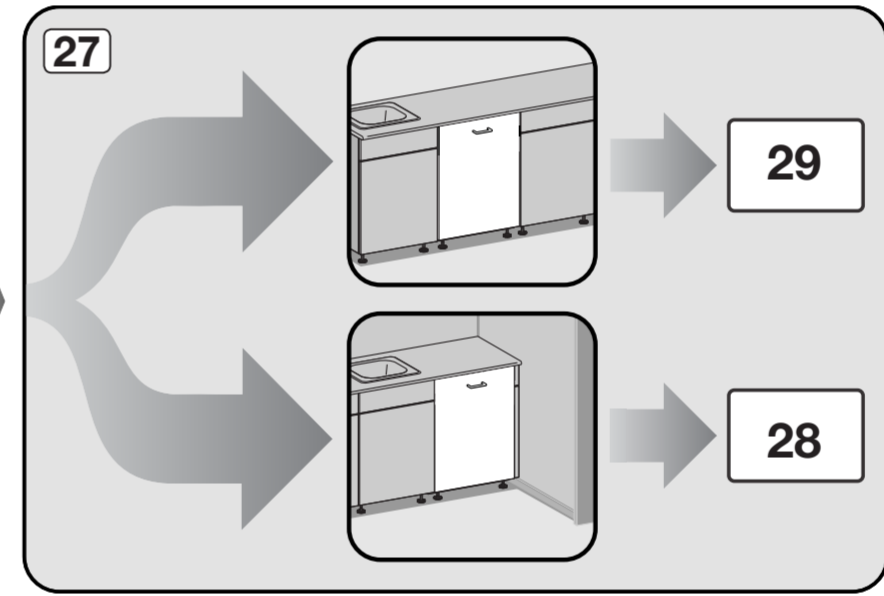
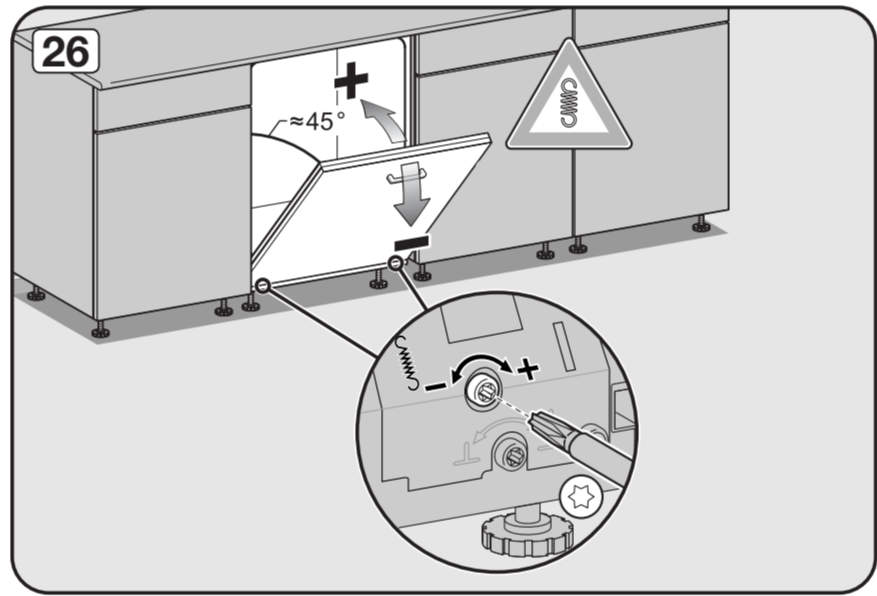
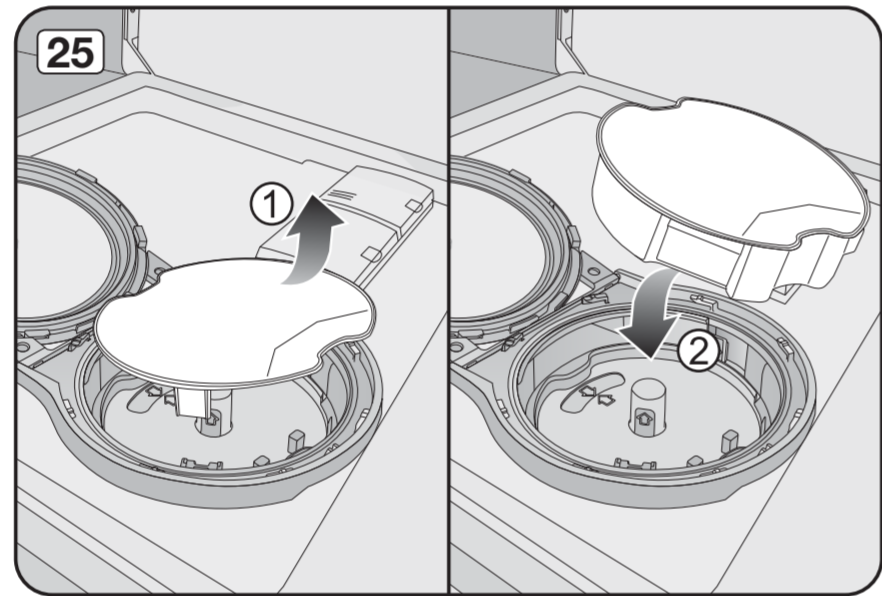
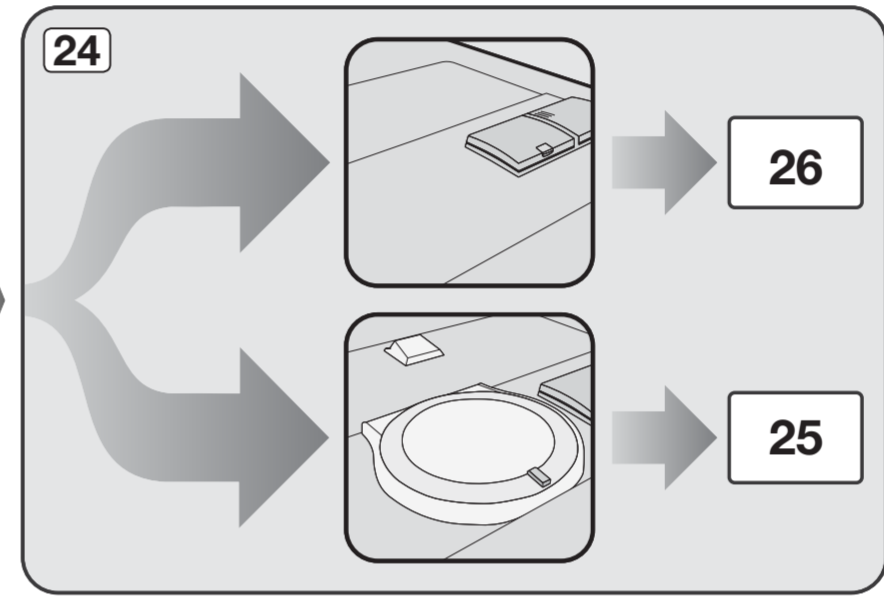
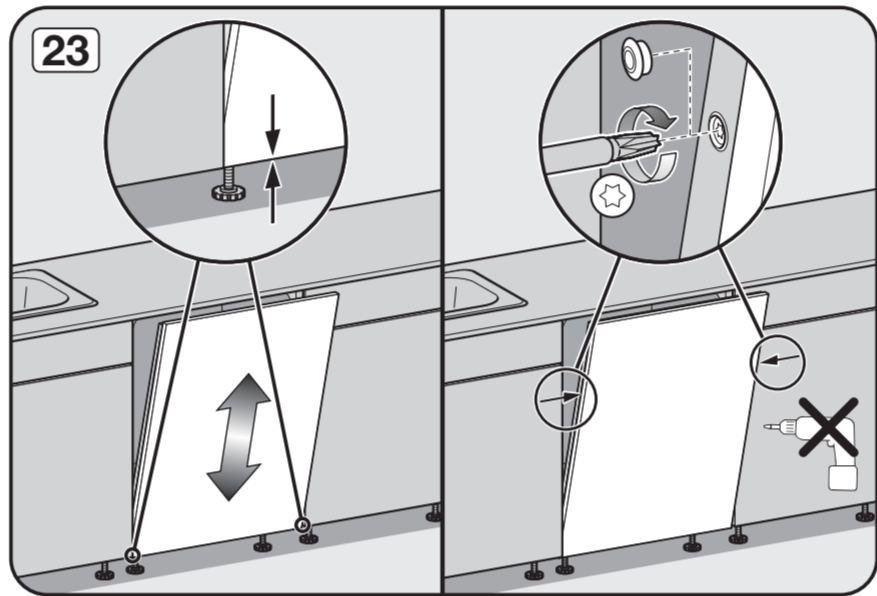
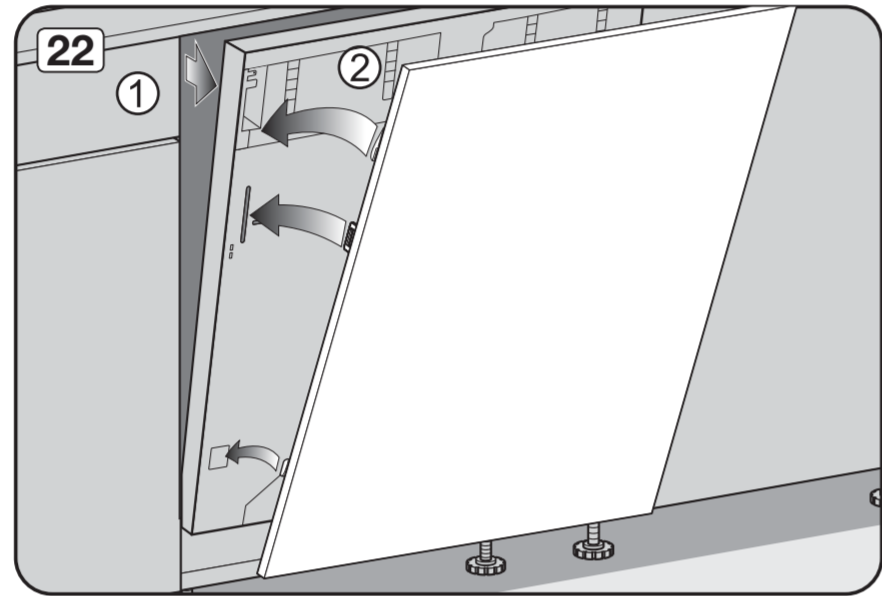
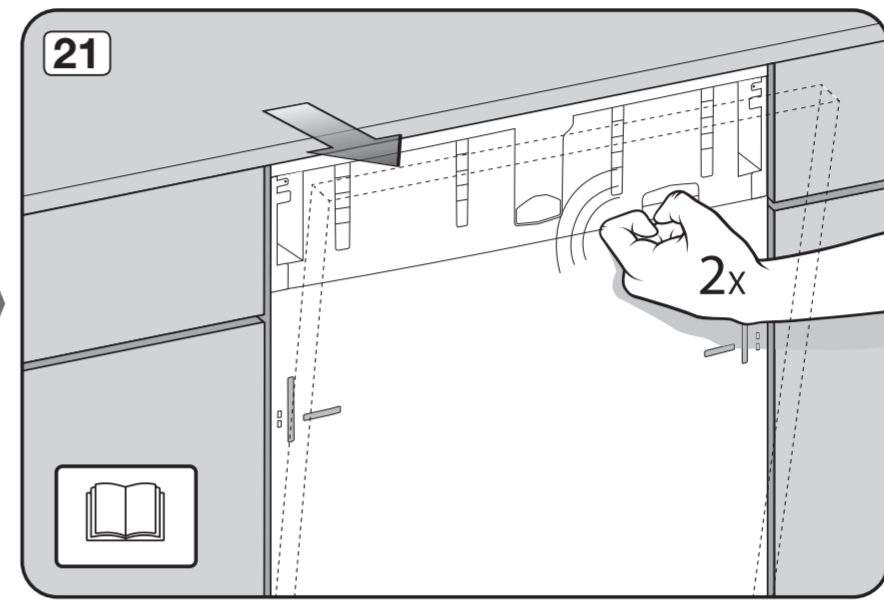
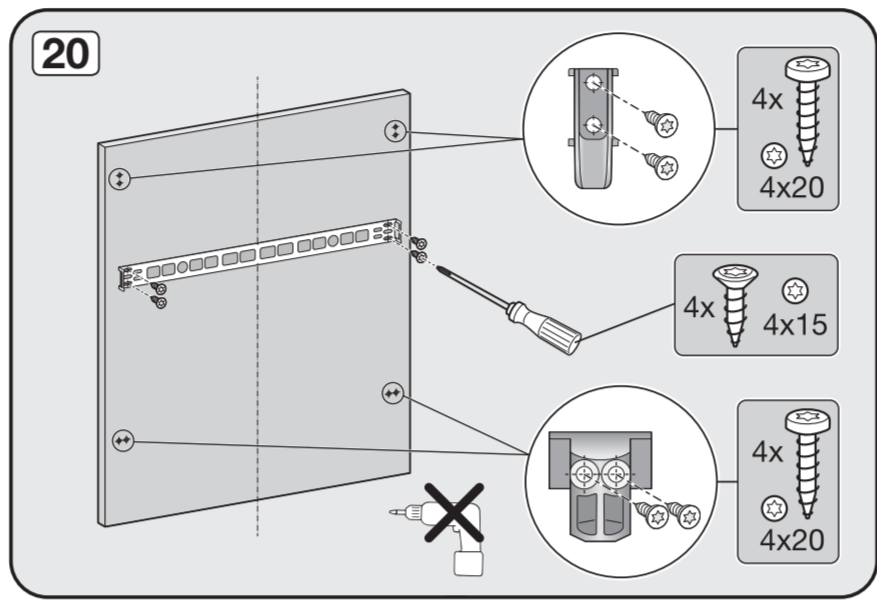
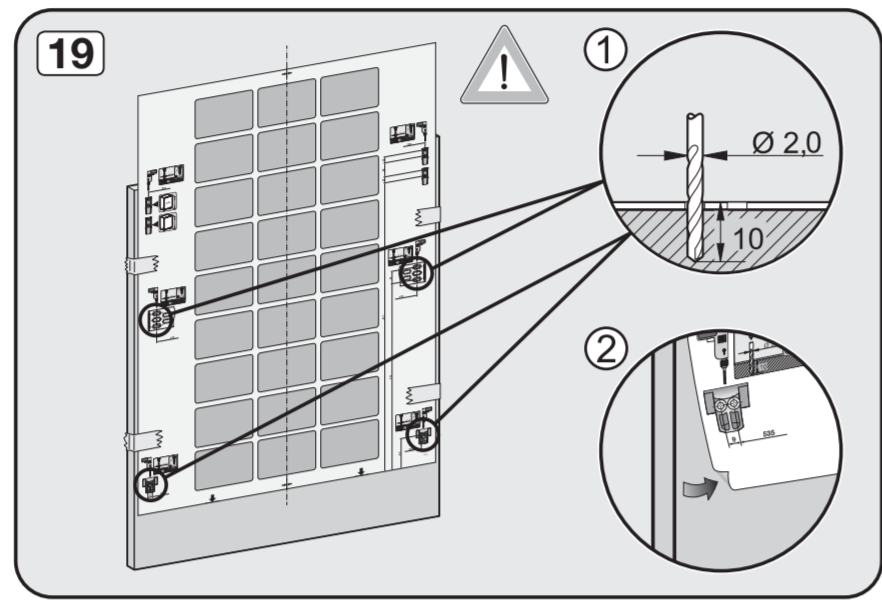
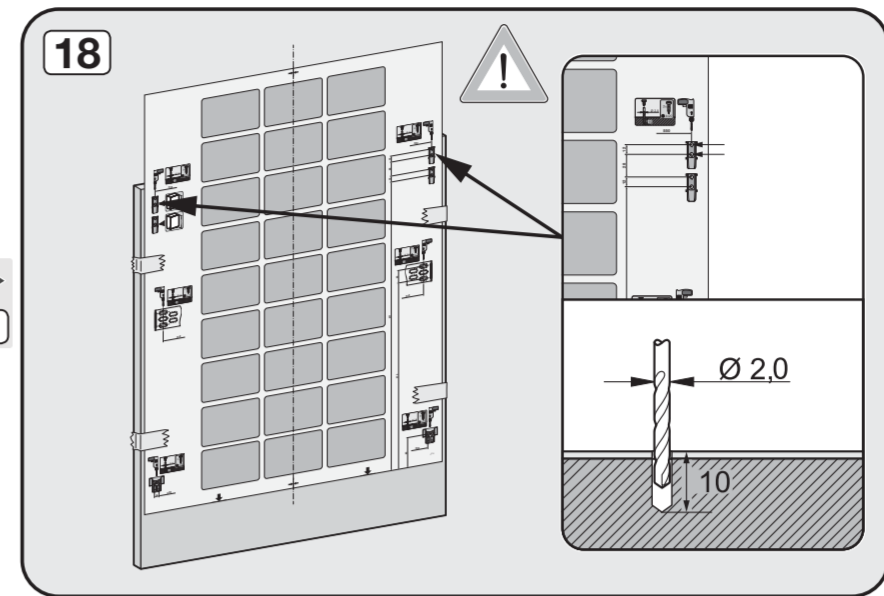
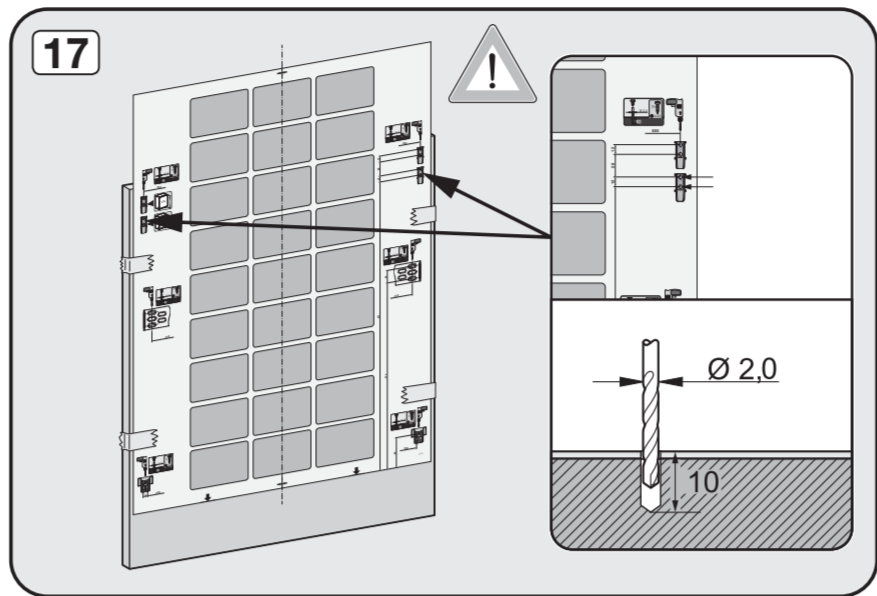
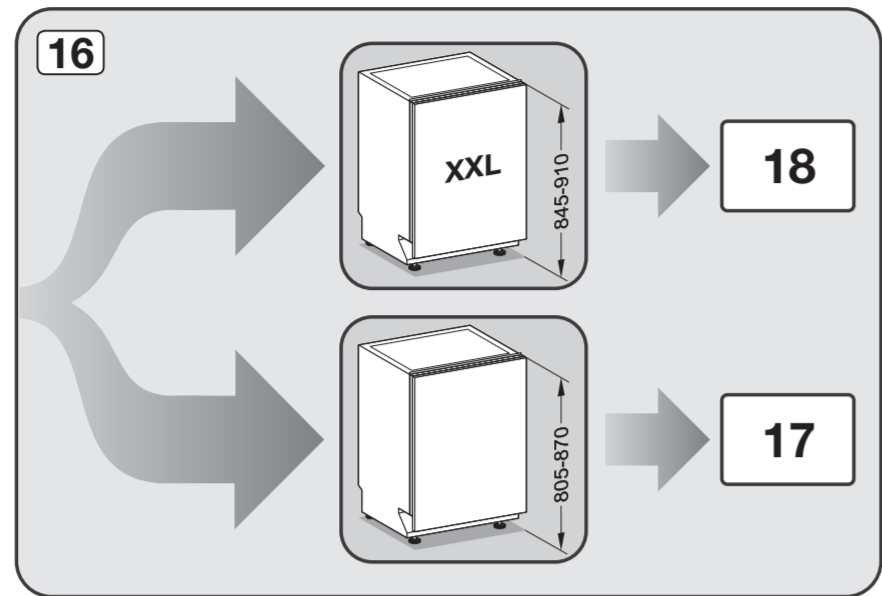
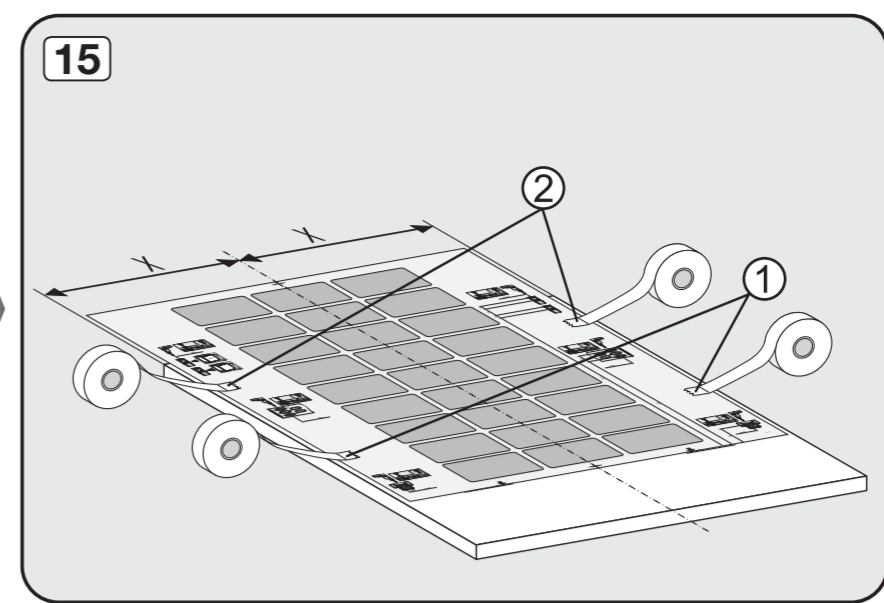
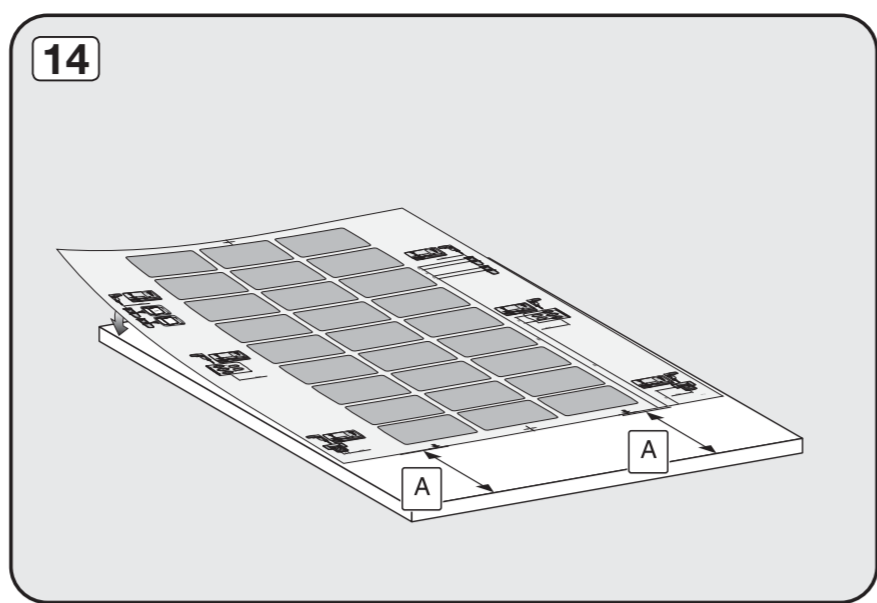
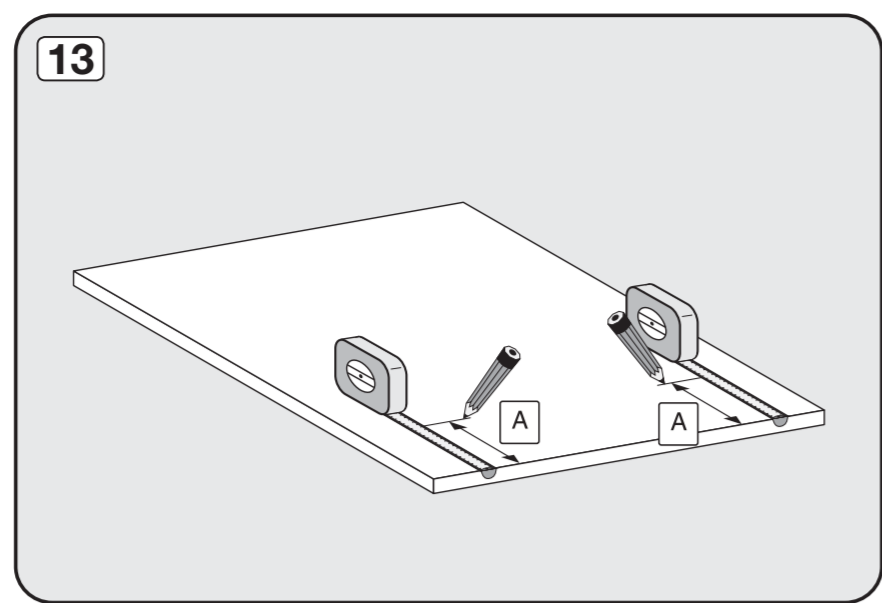

577

373